

October 1 2008



The company name  
was changed to  
**TOKYO KEIKI INC.**

2-16-46, Minami-Kamata, Ohta-Ku,  
Tokyo 144-8551, JAPAN  
TEL.+81-3-3732-2111  
FAX.+81-3-3736-0261  
<http://www.tokyo-keiki.co.jp/>

# Gyrocompass

## TG-8000/8500

TG-8000/8500 is designed based on our previous TG model which has been installed on more than 8000 ships, keeping its high reliability, enhanced follow-up performance and interfacing features for equipment.

The TG-8000 is designed for standard IMO ship application whereas the TG-8500 is designed for High-Speed Craft application.



### Features

- Suitable for speeds of up to 70knots (TG-8500)
- Fast follow-up rate (maximum 75 %/s)
- Fast serial data output (IEC61162-2)
- Interfaces with external heading sensor.
- Minimal system components for dual gyro system for space saving & installation cost.
- Startup-timer function

TG-8000 : IMO regulated vessels  
 IMO A424( ) ISO 8728  
 TG-8500 : High Speed Craft  
 IMO A82(19) ISO 16328 HSC

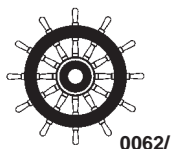

## Configurations

### Master compass

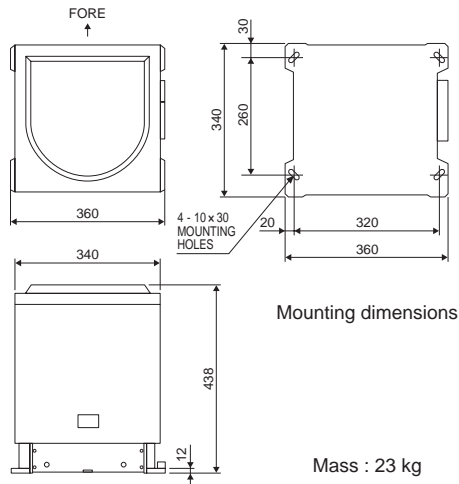

### Control unit

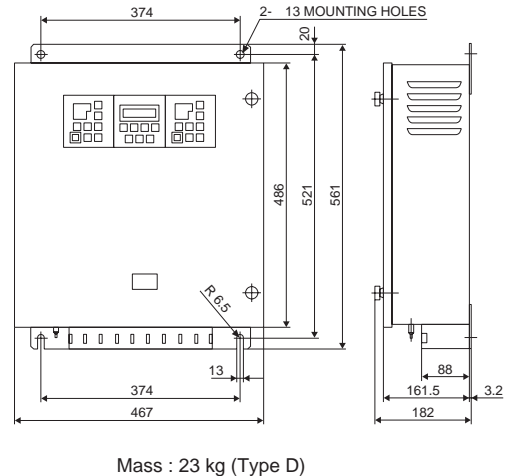
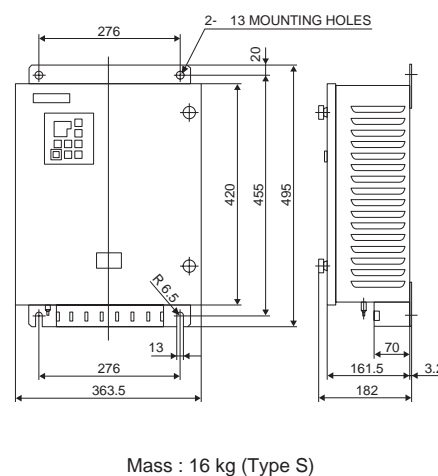

## Specifications

### General Specifications

#### Power Supply

Main Power Supply : AC100/110/115/220 V 1 50/60 Hz  
 Emergency Power Supply : DC24 V

#### Power Consumption

Starting : 140 VA  
 Operating : 70 VA  
 Repeaters : 150 VA 1/6° 3 9 Ports

#### Output Signal

: DC24 V Stepper, 9 Repeaters (include Auto Pilot)  
 : IEC61162-1ed.2 or IEC61162-2 5 ports (include Auto Pilot)  
 : Rate of turn -5 V ~ +5 V/30° / min  
 -10 V ~ +10 V/120° or 300° /min 3 ports  
 : Dry Contact (Operation, Alarm)

#### Input Signal

: Speed : 200 or 400 pulses/nm (Dry contact)  
 : IEC61162-1ed.2  
 : Position (GPS) : IEC61162-1ed.2  
 : External Heading Input : IEC61162-1ed.2 or IEC61162-2  
 : Dry Contact (Alarm Ack, Buzzer Stop)

### Performance Specifications

#### Settling Accuracy

Settling Time : Less than 4 hours  
 Settling Point Error : Less than  $\pm 0.3^\circ$   
 RSM Value : Less than  $0.1^\circ$   
 Repeatability : Less than  $\pm 0.2^\circ$   
 Accuracy on Scorsby Table : Less than  $\pm 0.5^\circ$   
 Master-compass follow up rate : Maximum  $75^\circ / s$   
 Accuracy Under Environmental Variation : Less than  $\pm 0.5^\circ$  (Condition : ISO8728 / ISO16328)

#### Environmental Conditions

Permissible Roll and Pitch angle :  $\pm 45^\circ$



CAUTION

Before operating this equipment, you should first thoroughly read the operator's manual.

Design and specifications are subject to change without prior notice and without any obligation the part of the manufacturer.

# TOKIMEC

## TOKIMEC INC.

[www.tokimec.co.jp/marine/](http://www.tokimec.co.jp/marine/)

Control Division Marine Systems

Head Office:

2-16-46, Minami-Kamata, Ohta-ku, Tokyo 144-8551, JAPAN  
 Phone : +81-3-3737-8611 Fax : +81-3-3737-8663

Shanghai Representative Office:

Room 805, Part C of Orient International Plaza,  
 No.85 Lou Shan Guan Road, Shanghai 200336 China  
 Phone : +86-21-3223-1252 Fax : +86-21-6278-7667

TOKIMEC U.S.A., INC.

445 South Figueroa St. Suite 3770, Los Angeles, California 90071 U.S.A.  
 Phone : +1-213-689-4747 FAX: +1-213-689-0303